

EXPANSION JOINT EPDM OR NBR PN10



ISO 9001 : 2008



Size : DN 32 to 600
Ends : Flanges GN10/16
Min Temperature : - 10°C
Max Temperature : + 100°C for EPDM and +80°C for NBR
Max Pressure : 10 Bars up to DN 250
Specifications : Absorb vibrations and noises
Linear and angular compansion
Single sphere

Materials : Galvanized steel flanges

EXPANSION JOINT EPDM OR NBR PN10

SPECIFICATIONS :

- Absorb vibration, noises and expansion
- Linear and angular compansion
- Single sphere EPDM (red logo) or NBR (orange logo)
- Galvanized steel flanges GN10/16
- Expansion limiter (option)

Marking example (EPDM):



USE :

- Water distribution (for EPDM types)
- Oil, hydrocarbon, air (for NBR types)
- Min and max Temperature Ts : - 10°C to + 100°C for EPDM types (Ref.1501 and 1502)
- Min and max Temperature Ts : - 10°C to + 80°C for NBR type (Ref.1503)
- Max Pressure Ps : 10 bars up to DN250 (see graph) , 7 bars over

PRESSURE / TEMPERATURE GRAPH (STEAM EXCLUDED) :

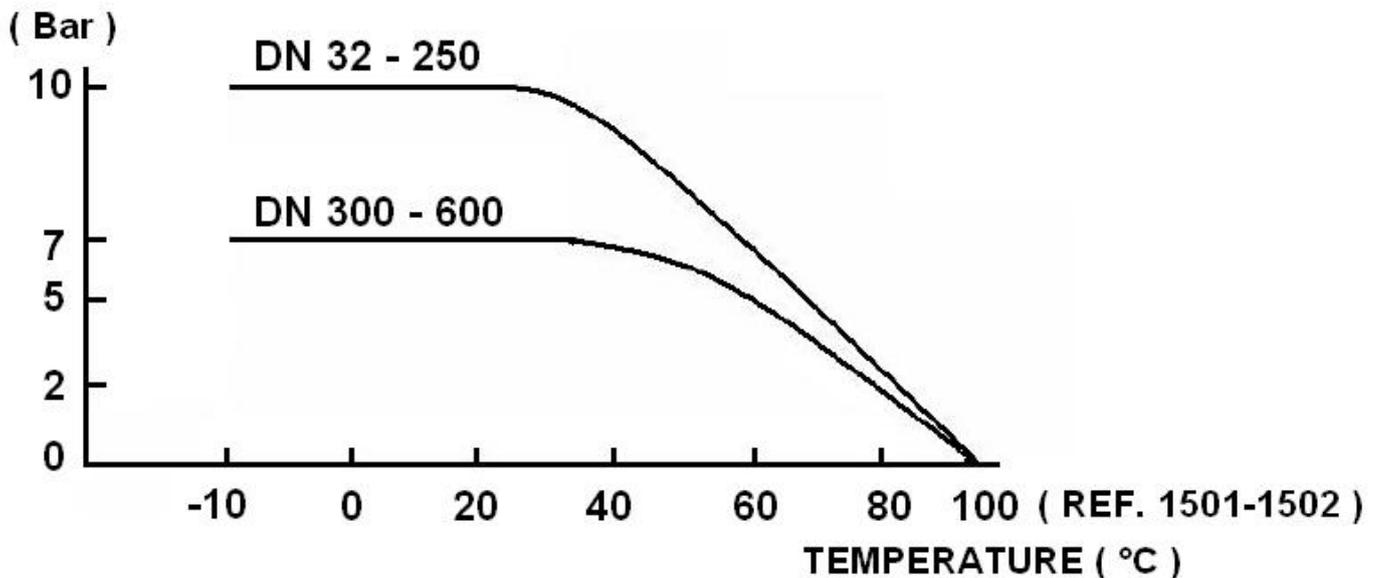

RANGE :

- EPDM expansion joint with steel flanges GN10 from DN 32 to DN 600 **Ref. 1501**
- EPDM expansion joint with steel flanges GN16 from DN 200 to DN 300 **Ref. 1502**
- NBR expansion joint with steel flanges GN10 from DN 32 to DN 200 **Ref. 1503**
- Expansion limiter (with 2 studs and 4 plates included) GN10 from DN 32 to DN 600 **Ref. 98604**
- Expansion limiter (with 2 studs and 4 plates included) GN16 from DN 200 to DN 300 **Ref. 98603**

EXPANSION JOINT EPDM OR NBR PN10

MATERIALS :

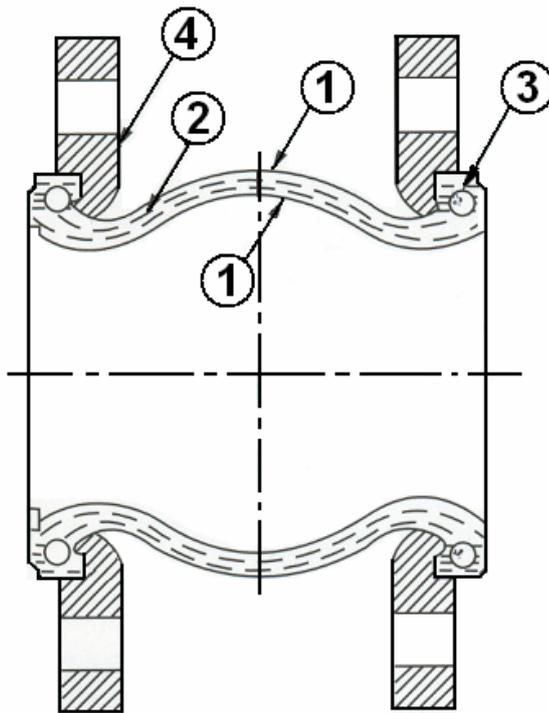

Item	Designation	Materials 1501 - 1502	Materials 1503
1	Bellow	EPDM	NBR
2	Reinforcement	Nylon cord	
3	Brace	Hard steel	
4	Flanges	Galvanized steel	

EXPANSION JOINT EPDM OR NBR PN10

SIZE (in mm) :

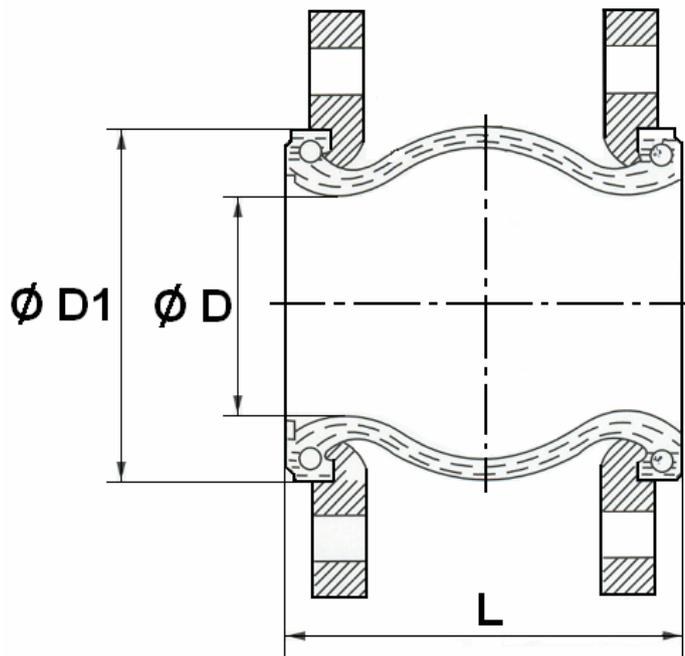

	DN	32	40	50	65	80	100	125	150	200	250	300	350	400	450	500	600
Ref.	L	95	95	105	115	130	135	170	180	205	240	260	265	265	265	265	265
	Ø D	40	40	52	68	76	103	128	152	194	250	300	320	372	415	454	580
1503	Ø D1	69	69	85	106	116	150	180	209	260	320	367	408	472	522	570	690
1501	Weight (Kg)	2.79	3.59	4.23	4.74	6.27	6.47	9.4	12.75	17.73	23.27	29.4	41.3	46.85	55.18	65	74.5
1502	Weight (Kg)									17.87	26	33.13					
1503	Weight (Kg)	2.95	3.46	3.98	4.89	6.57	6.74	9.36	12.71	16.80							

EXPANSION JOINT EPDM OR NBR PN10

MOVEMENTS (in mm) :

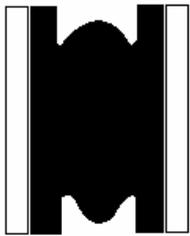

Compansion

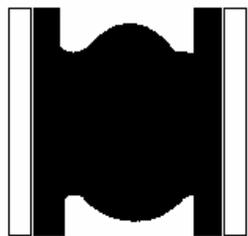

Expansion

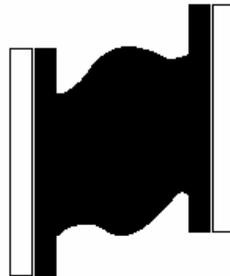

Lateral

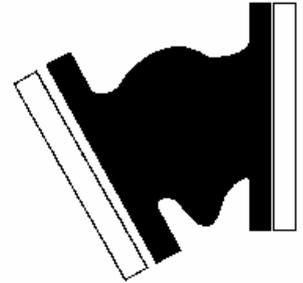

Angular

DN	32	40	50	65	80	100	125	150	200	250	300	350	400	450	500	600
Compansion	8	8	8	12	12	18	18	18	25	25	25	25	25	25	25	25
Expansion	4	4	5	6	6	10	10	10	14	14	14	16	16	16	16	16
Lateral	8	8	8	10	10	12	12	12	22	22	22	22	22	22	22	22
Angular	15°	15°	15°	15°	15°	15°	15°	15°	15°	15°	15°	15°	15°	15°	15°	15°

STANDARDS :

- Fabrication according to ISO 9001 : 2008
- DIRECTIVE 97/23/CE : Products excluded from directive (article 1, § 3.2)
- Flanges according to EN 1092 PN10/16

ADVICE : Our opinion and our advice are not guaranteed and SFERACO shall not be liable for the consequences of damages. The customer must check the right choice of the products with the real service conditions.

EXPANSION JOINT EPDM OR NBR PN10

INSTALLATION INSTRUCTION :

Expansion joint are designed for the absorption of previously specified movements under specific pressure and temperature conditions. So that the maximum service life is achieved, the following items must be observed during installation.

- Prior to fitment of the compensator it must be ensured that :
 - The route of the pipeline is straight - The expansion tallies with that of the chosen compensator
 - The expansion tallies with that of The chosen compensator
 - The fixes points are dimensionned so that they can absorb the reaction forces and stiffness rate that arise during use.
 - The pipeline is limited by fixed points
 - The distance between compensator and bearing may be a maximum of 3 times the pipe diameter. Place only one compensator between 2 bearings.
- Each pipe elbow must be fixed by support, specially if compensator is mounted with limiters. Fixed bearings are necessary because compensator is submitted to expansion when it is under pressure.
- Expansion joint must not be painted and heat-insulated. It must be protected from bad weather and solar radiation.
- During assembly operation, make sure screws are oriented according to the graph out below :

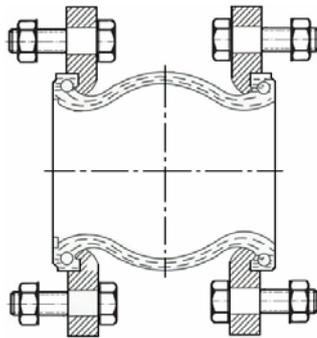

- Please apply the following stages order :
 - a) Fixed points for above pipeline
 - b) Fixed points for down pipeline
 - c) Compensator mounting

- Installation layout :

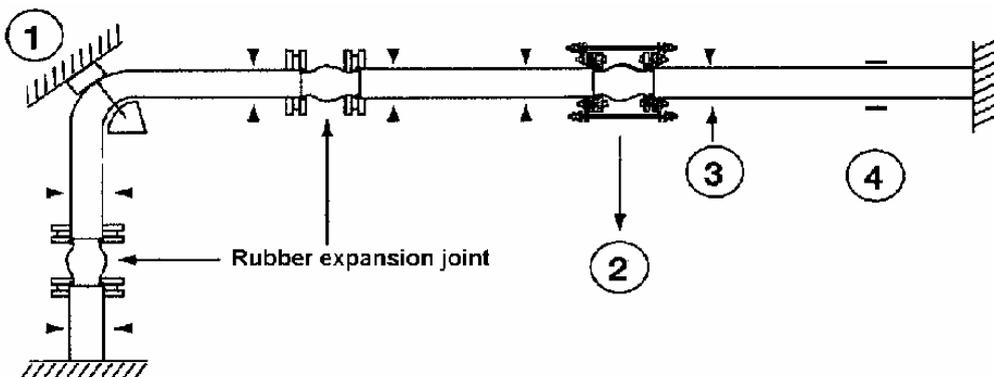

- Check that the compensator is not subjected to the weight of the pipeline. The installation lenght must agree with the installation gap. The compensator must never be twisted. It is recommended that specific characteristics be observed during maintenance :
 - The compensator must never be painted or recovered by heat insulation
 - The tightness of the bolts must be checked often.
 - The flanges must be perfectly cleared

EXPANSION JOINT EPDM OR NBR PN10

INSTALLATION INSTRUCTION (SUITE) :

- Use limiters : When the working pressure can exceed the following values :
 - Up to DN100 : 10 bars
 - From DN125 to DN250 : 9 bars
 - From DN300 to DN350 : 6 bars
 - From DN400 to DN600 : 3 bars
 - When there is some risk of high pressure (pump starting) or high temperature.

NOTA : The life of compensator can vary because of working conditions (fluids, pressure, temperature), that is why it is necessary to check it regularly.

WRONG INSTALLATION :

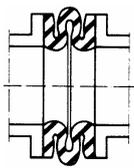

Excessive compansion

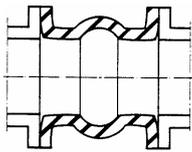

Excessive expansion

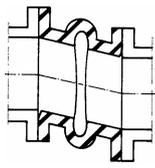

Cutting too important

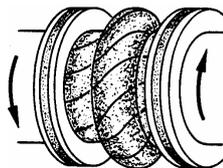

Torsion

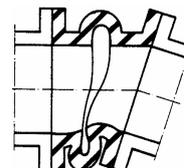

Important compansion and angular deviation

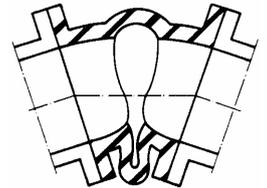

Angular deviation too important