

2 PIECES BALL VALVE PN63



Size : DN 1/4" to 3"
Ends : Threaded BSP or NPT
Min Temperature : -30°C in SS and -20°C in carbon steel
Max Temperature : + 180°C
Max Pressure : 63 Bars
Specifications : Anti blow-out stem
Locking device
Full bore

Materials : Carbon steel or Stainless steel

2 PIECES BALL VALVE PN63

SPECIFICATIONS :

- Full bore
- Anti blow-out stem
- PTFE packing
- Locking device
- Solid ball
- 2 pieces type

USE :

- For all common fluids
- Min and max Temperature Ts : -20°C to + 180°C for carbon steel type **Ref. 705**
- Min and max Temperature Ts : -30°C à + 180°C for stainless steel types **Ref. 704-706**
- Max Pressure Ps : 63 bars up to DN3/4",50 bars from DN 1" to 1"1/4,40 bars from DN 1"1/2 to 2" , 25 bars from DN 2"1/2 to 3" (see graph)

PRESSURE / TEMPERATURE GRAPH (STEAM EXCLUDED) :

PRESSURE

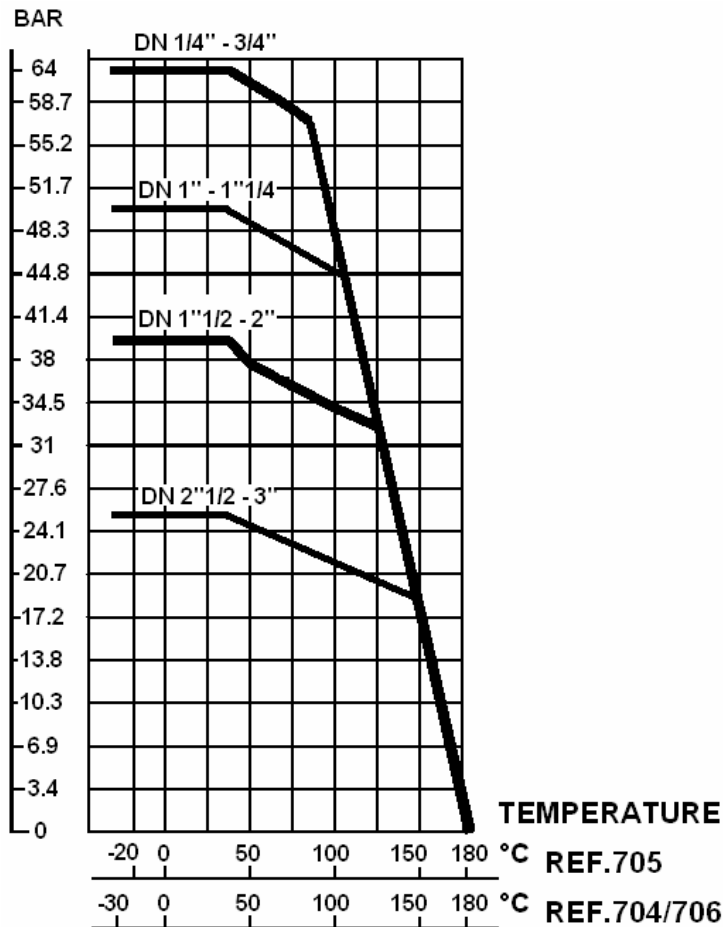

2 PIECES BALL VALVE PN63

RANGE :

- Stainless steel with red handle **Ref. 704** DN 1/4" to DN 2"
- Carbon steel with red handle **Ref. 705** DN 1/4" to DN 3"
- Stainless steel with red handle **Ref. 706** DN 1/4" to DN 3"
- Stainless steel with red butterfly handle **Ref. 7061** DN 1/4" to DN 1"

ENDS :

- Female / female threaded BSP cylindric **Ref. 705/706**
- Female / female threaded NPT cylindric **Ref. 704**

MATERIALS :

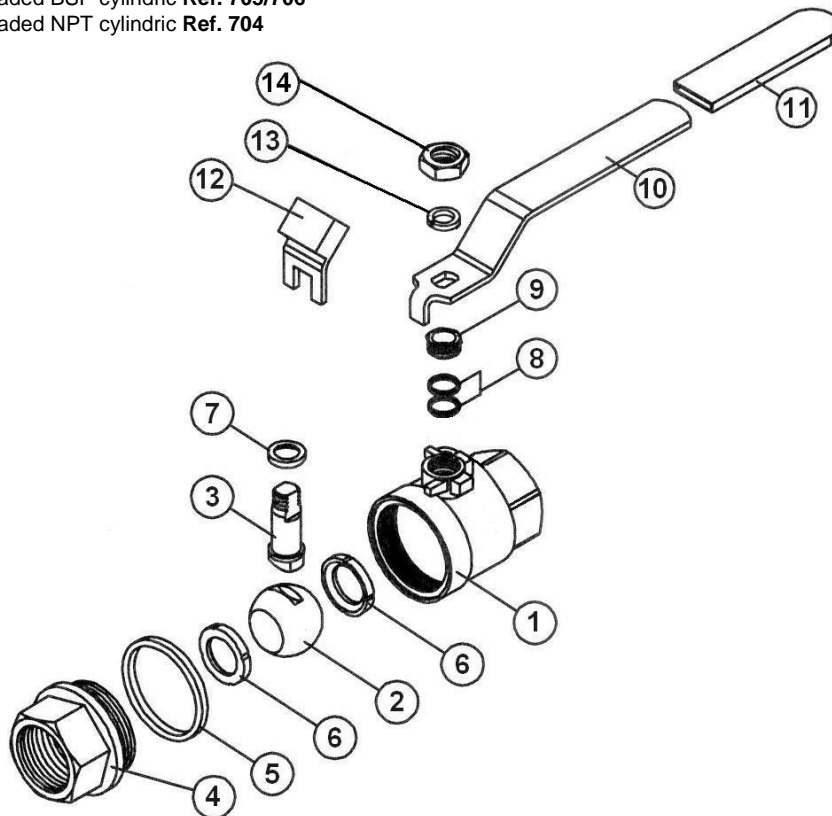

Item	Designation	Materials 704/706	Materials 705
1	Body	ASTM A351 CF8M	ASTM A216 WCB
2	Ball	ASTM A351 CF8M	
3	Stem	SS 316	SS 304
4	Bonnet	ASTM A351 CF8M	ASTM A216 WCB
5	Body seal	PTFE	
6	Seat	PTFE filled with 15% glass	
7	Stem gasket	PTFE	
8	Packing	PTFE	
9	Packing nut	SS 304	
10	Handle	SS 304	
11	Handle cover	Plastic	
12	Locking device	SS 304	
13	Washer	SS 304	
14	Handle nut	SS 304	

2 PIECES BALL VALVE PN63

SIZE (in mm) :

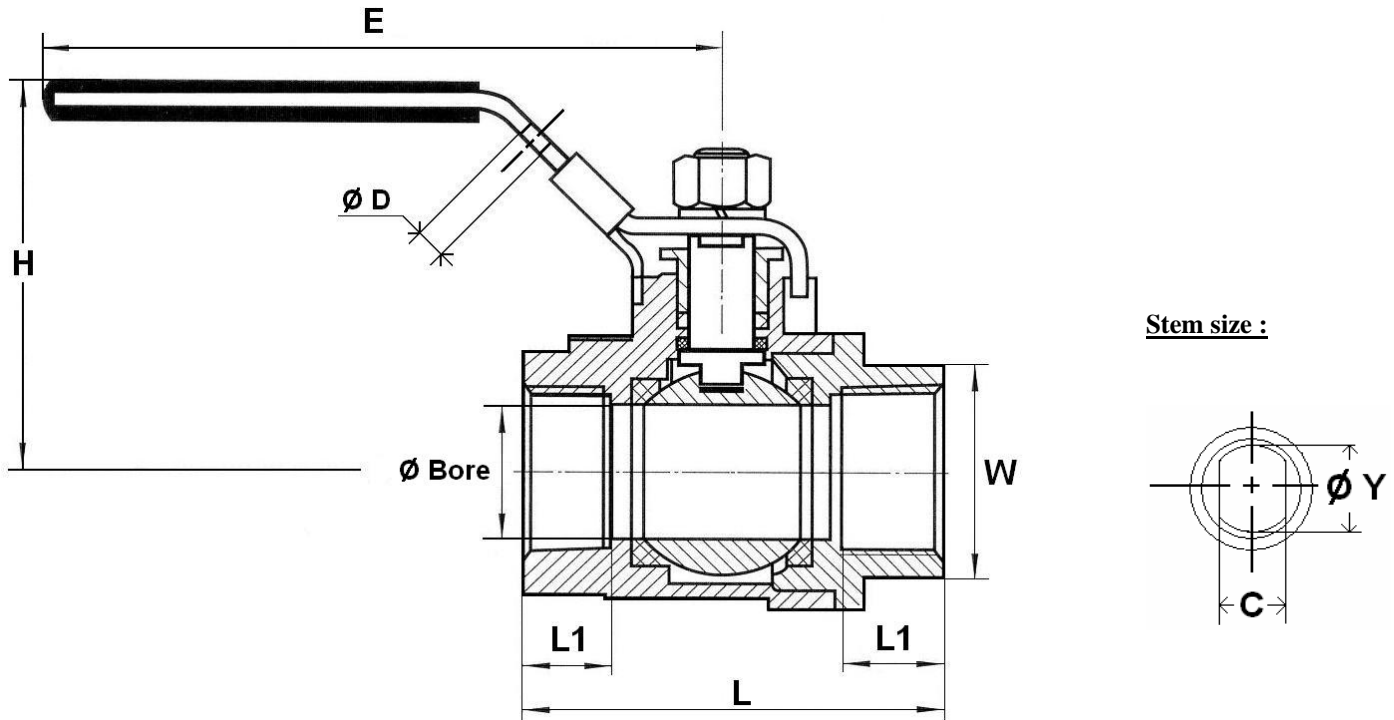

Stem size :

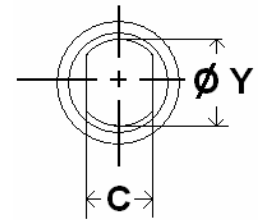

	DN	1/4"	3/8"	1/2"	3/4"	1"	1"1/4	1"1/2	2"	2"1/2	3"
Ref.	Ø Bore	9.2	12.5	15	20	25	32	38	50	65	80
	L	48.6	52.5	59	65	76	90	102	122	157	176
704/705	Ø D	8	8	8	8	8	8	8	8	8	8
	E	81	87	100	100	148	148	190	190	280	280
706	H	47.5	52	56.5	58.5	74	78	92	103	118	127
	L1	10	12	14.5	16	18	19	20	22	28	32
	W on flat	19	22	26	32	38	50	54	68	85	98
	C	4	5	6.5	6.5	8	8	8.5	8.5	12	12
	Ø Y	6	7	7.5	7.5	9	9	11	11	15.5	15.5
	Weight (Kg)	0.24	0.25	0.29	0.44	0.72	1.2	1.82	2.74	5.15	7.2

2 PIECES BALL VALVE PN63

BUTTERFLY HANDLE SIZE (in mm) :

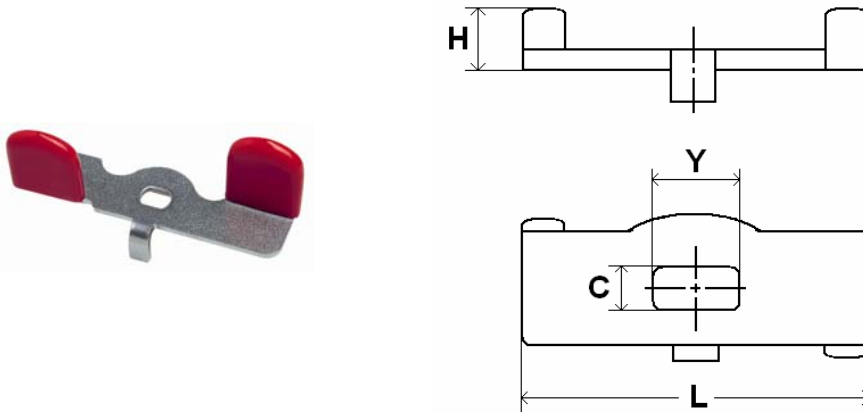

- **Ref. 983113 :**

DN	1/4"	3/8"	1/2"	3/4"	1"
L	55	55	60	60	70
H	20	20	22	22	28
C	4	5	6.5	6.5	8
Y	7	8	9.5	9.5	11.5

TORQUE VALUES (in Nm without safety coefficient) :

DN	1/4"	3/8"	1/2"	3/4"	1"	1"1/4"	1"1/2"	2"	2"1/2"	3"
Torque (Nm)	2.7	2.7	3	4	5	6	8	10	40	60

2 PIECES BALL VALVE PN63

STANDARDS :

- Fabrication according to ISO 9001
- DIRECTIVE 97/23/CE : CE N° 0036
Risk category II
- Tests according to EN 12266
- Thread ends BSP cylindric according to ISO 228-1 and DIN 2999

ADVICE : Our opinion and our advice are not guaranteed and SFERACO shall not be liable for the consequences of damages. The customer must check the right choice of the products with the real service conditions.

INSTALLATION AND MAINTENANCE

BEFORE INSTALLATION :

Pipe-line must be cleaned and free from residual of weldings, rubbish, shaving and every kind of extraneous materials. Pipe-line must be perfectly aligned and their support properly dimensioned so that there's no external constraint.

Please use the right product according to the services conditions to seal the valve.
Use the right bolt tightening so that the ends won't be damaged.

CLEANING AND TESTS

Keep closed the valves during the cleaning operation so that there's no impurities between the ball and the body.

Tests under pressure must be done with a cleaned pipe-line.

Open partially the valve for tests. Pressure test do not exceed the valve specifications according to EN 12266-1.

MAITENANCE

It's recommended to operate the valve twice (open and close) 1 to 2 times per year.

When intervention on the valve, be sure there's no pressure in the pipe-line, there's no fluid in it, and that it is isolated. The temperature must be low enough to operate without risks.
If there's a corrosive fluid, inert installation before intervention.

When the valve is under pressure :

If there's a leakage at the packing, tighten it slightly so that the leakage disappears.